



S / SC Series

Operation and Safety Manual

Purifico Ozone Inc.

9409 45 Ave NW Edmonton, AB T6E 6B9 Phone: 780 930 2929

www.purifico-ozone.com

Contents

Introduction	5
A. Ozone & ORP Overview	6
How Ozone is Generated	6
Properties of Ozone	6
Oxidation Reduction Potential (ORP)	6
B. Safety	7
Ozone Gas	7
High Voltage:	7
General Safety Practices:	8
Personal Protective Equipment (PPE):	8
Ventilation:	8
Ozone Detection:	8
Training:	8
Emergency Procedures:	8
Maintenance:	8
Regulatory Compliance:	8
Installation and Electrical Safety:	8
C. Purifico Ozone Inc. S / SC Series	9
Air Preparation System	9
Ozone Generator	9
System Overview	10
D. Safety Features and Controls	14
Safety Features	14
Optional Controls	14
Gauges	14
ORP Sensor	15
Calibration	15
Probe Cleaning	15
Replacement of Salt Bridge	15
Storage	16
Mazzei Pressure Sensors	16
ARK™ Flood Sensor	16
Ambient Ozone Monitor	17
Air Prep System	17
Air flow meter	17

Oxygen pressure gauge	17
Desiccant dryer	17
E. Operations	18
Home Screen Features	18
Settings Overview	20
Password Protection	20
Modes of Operation	21
Automatic Ozone Output Mode	21
Manual Ozone Output Mode	21
Mazzei Sensor	22
Ambient Sensor(s)	22
Automatic Restart	23
Manual Restart	23
Time Off Delay	23
Recirculation Pump	24
Bypass Sensors	24
Ozone Cell Reset	25
Water Quality Alerts	26
Backup/Restore	26
ORP Calibration	27
System Info	28
Alarm Log	28
Date/Time	28
Service Hours	29
ORP History	30
F. Plumbing options	31
Flow-through	31
Side-stream	31
G. Maintenance	32
Daily Inspection	32
Weekly Maintenance	32
Annual /semi annual maintenance	32
H. Trouble Shooting	33
Air Preparation /Lower Cabinet	33
Ozone Generator	34

I. Responsibility Disclaimer	36
Environmental Requirements:	36
Appendix A - Safety Data Sheet	37
Appendix B – Potable Water Guidelines	40
Chlorine Requirements	40
Bromide Concentrations	40
Appendix C - Limited Warranty	41

Introduction

This Operation and Safety Manual is written to provide basic information on the operational procedures and safety requirements of the Purifico Ozone Inc. S / SC Series ozone water treatment module.

Please read through this manual and keep it handy for reference in maintenance requirements and troubleshooting.

Ozone water treatment systems use ozone to disinfect and purify water, using sophisticated electronics to direct and monitor the process. The Purifico Ozone Inc. S / SC Series have been designed to require minimal maintenance, but as with all equipment, routine inspection and maintenance are required to keep your system operating at its peak performance. As this equipment may be working 24/7, some wear and tear is expected. Regular inspection and prompt attention to any concerns will help to extend the effective lifespan of your system.

A.Ozone & ORP Overview

How Ozone is Generated

Ozone is generated by exposing diatomic oxygen molecules (O_2) in an air stream to a high energy electrical field. Exposure to these high levels of electrical energy causes a portion of the diatomic oxygen molecules to split into individual oxygen atoms (O_1). These oxygen atoms then recombine with diatomic oxygen molecules in the air stream, forming ozone (O_3).

Properties of Ozone

Ozone is effective in performing the following:

- **Disinfection:** Ozone effectively disinfects all types of organisms (bacteria, fungi, viruses, protozoa, etc.)
- **Oxidation of Inorganics:** Precipitates iron, manganese, sulfides, nitrides and organically-bound heavy metals
- **Oxidation of Organics:** Breaks down organic compounds (carbon based), eliminating problems with colour, taste and odor.

Oxidation Reduction Potential (ORP)

ORP represents the potential for oxidative (loss of electrons) or reductive (gain of electrons) reactions to occur in water. ORP is measured as an electrical current in millivolts (mV) using probes that are robust and reliable for industrial applications. ORP is a standard measurement used in water treatment, providing good estimation of water quality and disinfection levels. The ORP required for effective treatment depends on the constraints and goals of each application. The measurements will vary in different processes, depending on numerous factors relating to water quality. When commissioning a system, it is important to correlate ORP measurements with parameters of interest such as residual ozone, dissolved oxygen, and microbial testing or other analytical results. Once ORP levels yielding satisfactory outcomes have been established, ORP measurements can be relied on for routine monitoring.

B. Safety

When operating ozone water treatment systems, it is essential to adhere to best practices to ensure the safety of both workers and equipment. Ozone is a powerful oxidizing agent, and while it is highly effective in water treatment, it requires careful handling to prevent exposure and ensure proper operation. For detailed safety guidelines and procedures that must be adhered to, please refer to the appendix of this manual.

Two aspects of Purifico Ozone Inc. S / SC Series ozone generators represent potential dangers – oxygen/ozone gas, and high voltage electricity.

Ozone Gas

Purifico Ozone Inc.'s ozone generator is designed to operate under a pressure condition. While safety precautions have been taken, entering the equipment area should be avoided if ozone gas is detected. Ozone has a very distinctive odor and is usually detectable at low concentrations (0.02ppm), which is several times lower than typical 8-hour exposure limits. **DO NOT RELY ON ODOR AS A WARNING SYSTEM FOR UNSAFE OZONE CONCENTRATIONS.** Safety requirements differ regionally and based on infrastructure. **It is critical for the end-user to, at a minimum, understand and adhere to the regulations applicable to their situation.**

WARNING: High concentrations of ozone gas are dangerous to humans. Low concentrations can cause irritation to the eyes, throat, and respiratory system.

NOTE: If the smell of ozone is present
Shut down system
Ventilate the area



Oxidizer – May cause or intensify fire



Causes eye irritation. Causes damage to lungs if inhaled. Causes damage to the lungs through prolonged or repeated exposure if inhaled.



May cause damage to aquatic environment.

For additional information, see Appendix A - Safety Data Sheet

High Voltage:

The ozone generator has a high internal voltage and high capacitance. Proper care must be used by a qualified electrician when making any internal adjustments or performing any maintenance procedures.



WARNING: Purifico Ozone Inc.'s ozone generators operate at high voltage. Do not tamper with or deliberately bypass the safety switches built into the system. If contact is made with operating high voltage components, electric shock will occur. Do not rely exclusively on high voltage RED LED indicator for bus voltage, as dangerous voltage levels may remain even when the indicator is off.

Before any work is done on the unit, turn off the main power supply and lock it in the "off" position and wait 20 minutes before servicing. High voltage may be present even with all electrical power

supplies disconnected. Use an appropriate meter to verify that all CD bus capacitor banks have been discharged before working on any equipment.

General Safety Practices:

Personal Protective Equipment (PPE): Always wear appropriate PPE, including gloves, safety goggles, and protective clothing when handling ozone equipment.

Ventilation: Ensure the treatment area is well-ventilated to prevent the accumulation of ozone gas, which can be harmful if inhaled.

Ozone Detection: Use ozone detectors to monitor ozone levels in the workspace. This helps to ensure that ozone concentrations remain within safe limits.

Training: All personnel involved in the operation and maintenance of ozone water treatment systems should receive thorough training on the system's functionality and safety protocols.

Emergency Procedures: Establish and communicate clear emergency procedures in case of accidental ozone release or exposure.

Maintenance: Regularly inspect and maintain ozone generators and related equipment to ensure they are functioning correctly and safely.

Regulatory Compliance: Adhere to all local regulations and standards regarding workplace safety and ozone use. Compliance with these regulations is crucial for maintaining a safe and legally compliant work environment.

Installation and Electrical Safety:

- Basic safety precautions should always be followed when installing and using this equipment.
- All electrical connections should be made by a qualified electrician.
- This unit is designed for indoor use only.
- Connect to a grounded, grounding type receptacle only.
- Do not bury the cord.
- If the electrical cord is damaged, replace it immediately.
- If work is to be done on the system, lock main power switch in OFF position, and wait 20 minutes.
- **Never leave an ozone cabinet open and unattended.**

C. Purifico Ozone Inc. S / SC Series

Air Preparation System

The ozone generating cell requires a source of clean, dry, high-oxygen content air in order to efficiently produce ozone, making the air preparation system an integral part of the ozone system. This high concentration of oxygen is created through a high efficiency 10 lpm pressure swing adsorption (PSA) industrial oxygen concentrator. The standard molecular sieve beds of the oxygen concentrator deliver 93 +/- 3% pure oxygen. A desiccant air dryer further dries the air, enhancing the efficiency and lifespan of the ozone generating cell. Compressed air supplied to the oxygen concentrator, whether the standard sieve beds or an alternative unit, should be dry and free of oil vapors.

Consent from Purifico Ozone Inc. and adhering to the following guidelines is required before utilizing any alternative feed gas source, to maintain the warranty described in this manual. Oxygen feed must be filtered to 0.1 microns or less. The Plasma Block® uses aluminum and ceramic materials, providing safety for water purification. However, aluminum reacts with nitric acid produced by atmospheric air. Therefore, use only an oxygen concentrator or O₂ for feed gas. Ensure the feed gas has a dew point of at least -60°F (-51°C) and is 93% O₂ or higher.

BEFORE the system is energized for the first time the Plasma Block® should be pre-dried by flowing the above feed gas for 3 to 5 minutes. If the installed system will be dormant for long intervals, then the control system should do a pre-purge to ensure the system is dry before power is applied to the cell.

Ozone Generator

The S / SC Series utilize an air-cooled PTI PlasmaBlock® to generate a high quality ozone gas. It has been designed for long life under high electrical-loading conditions in harsh thermal environments. Using corona discharge, the ozone generator converts high concentration oxygen flowing through it into ozone when high voltage is applied.

System Overview

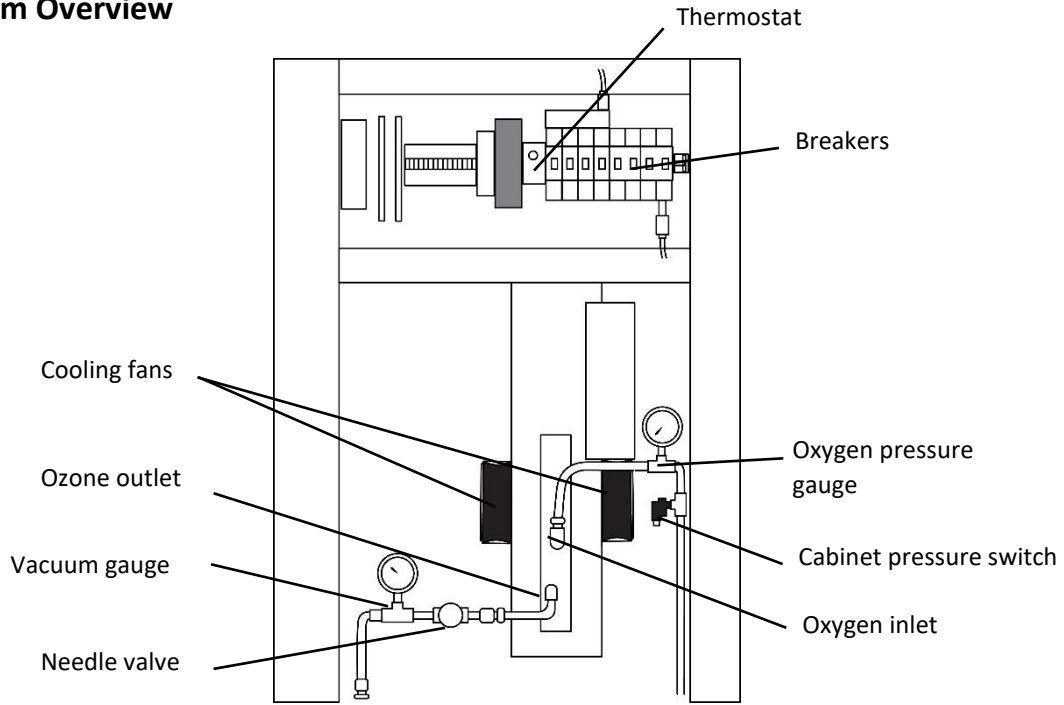

Top Cabinet

Note: Actual configuration and components may vary based on customization and size of ozone cell

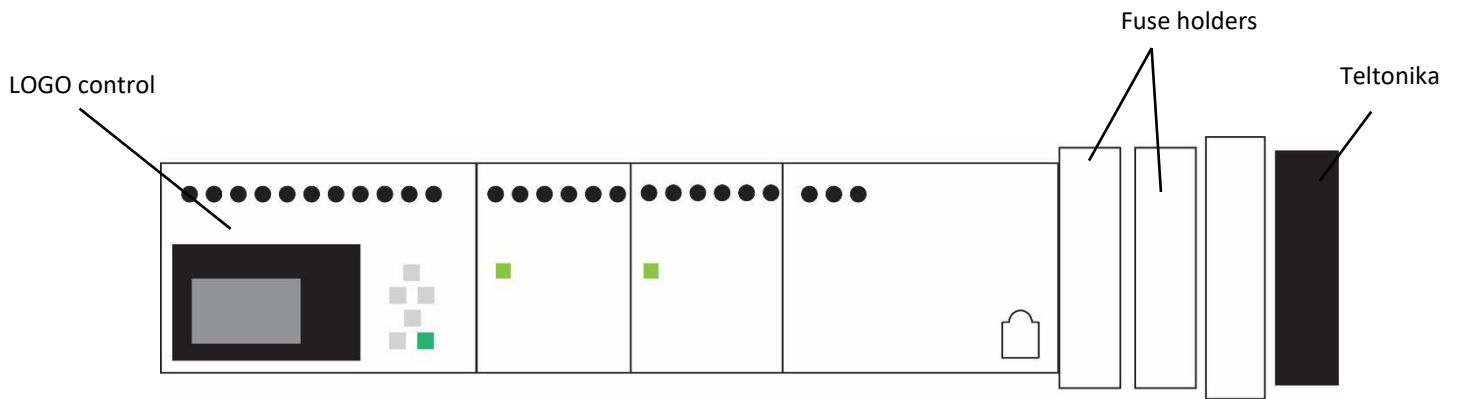

Side Cabinet

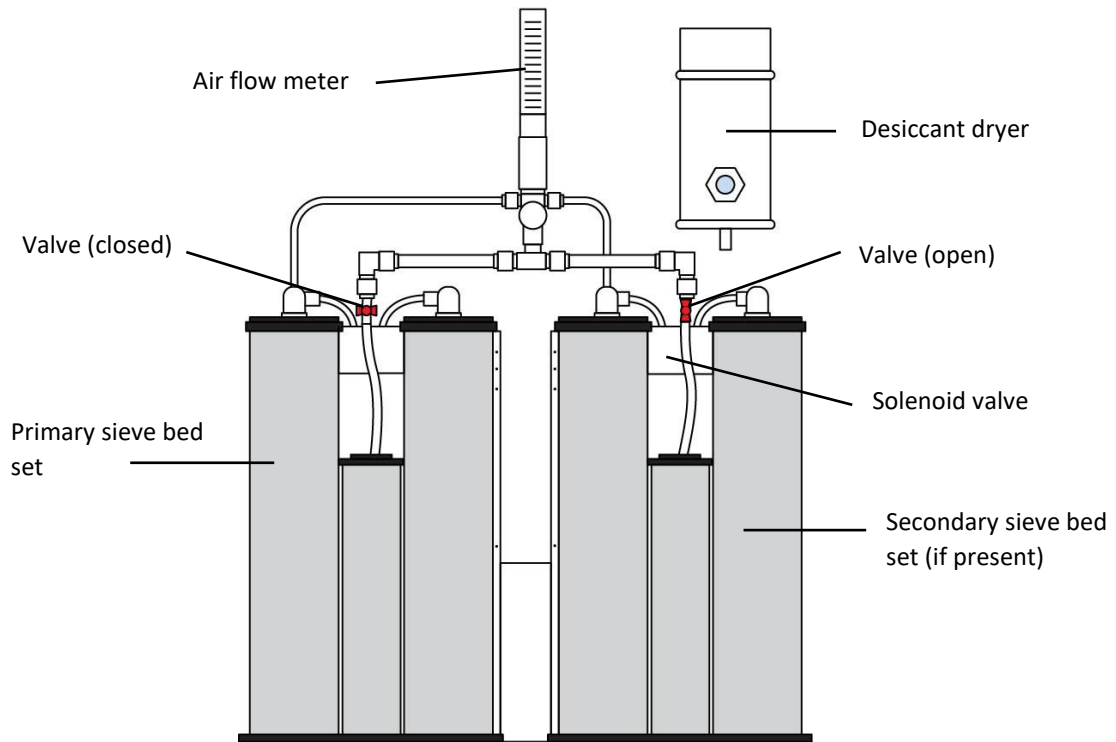

Bottom Cabinet – S Series
(no air reservoir tank shown)

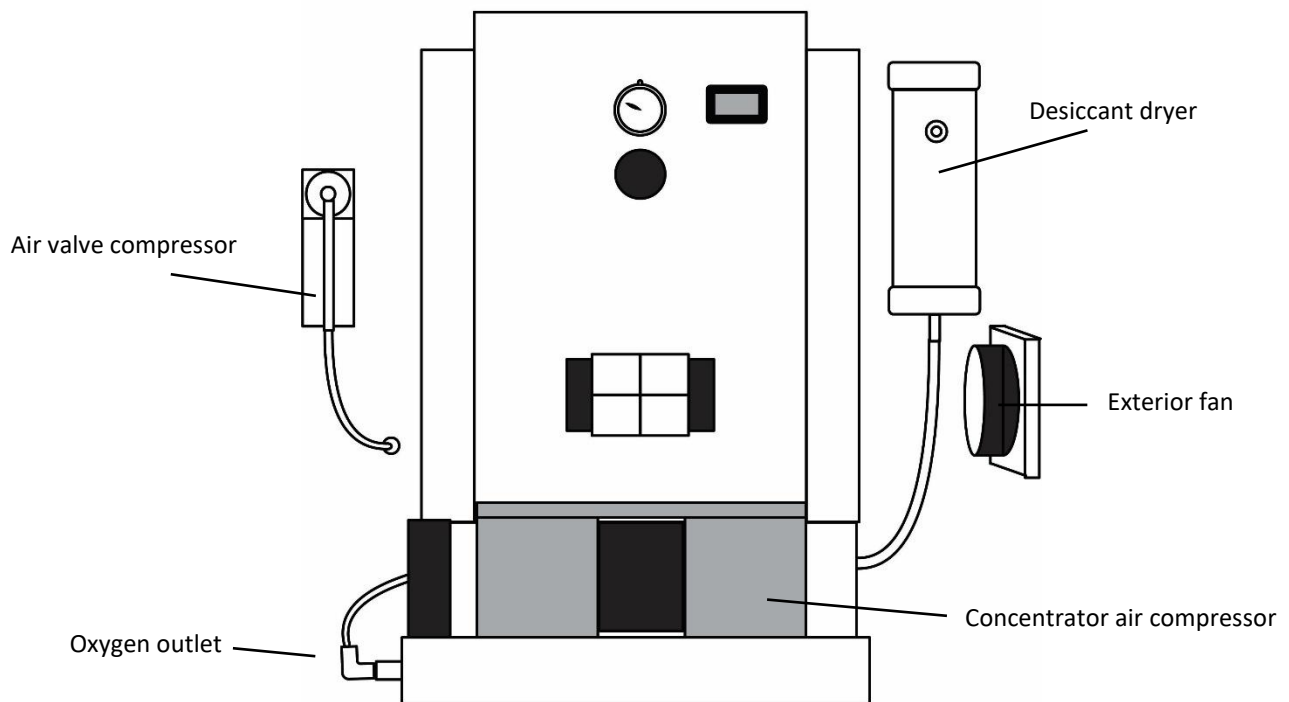
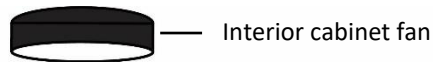

Bottom Cabinet – SC Series

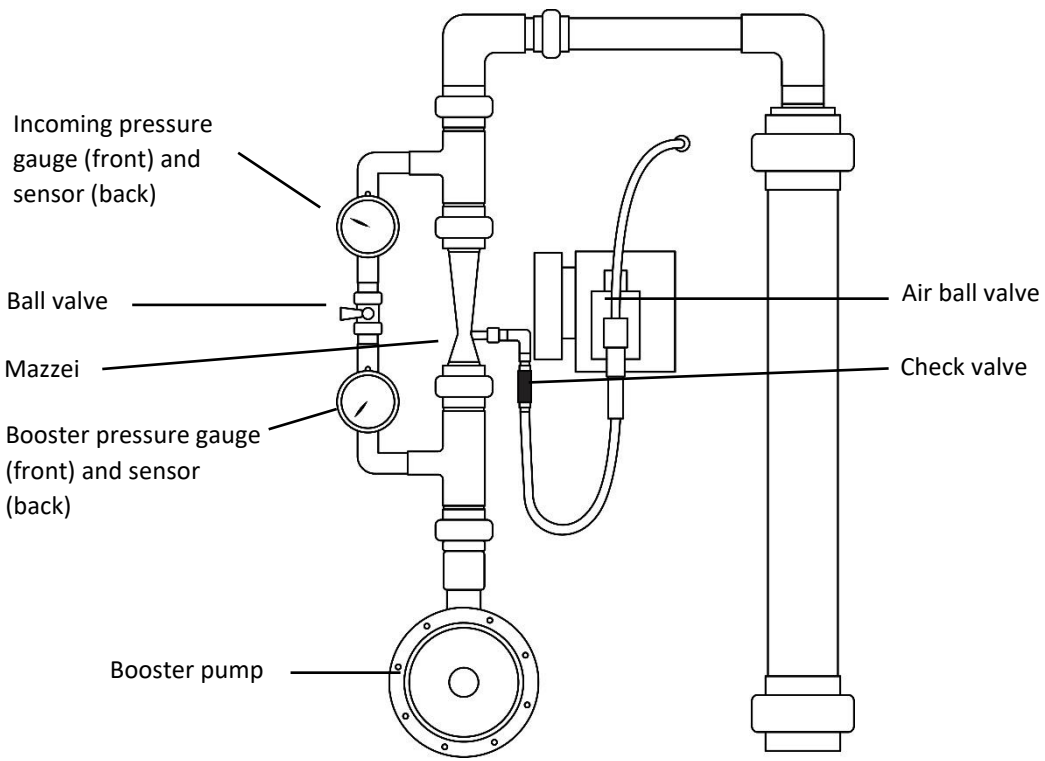

Mazzei Injection System

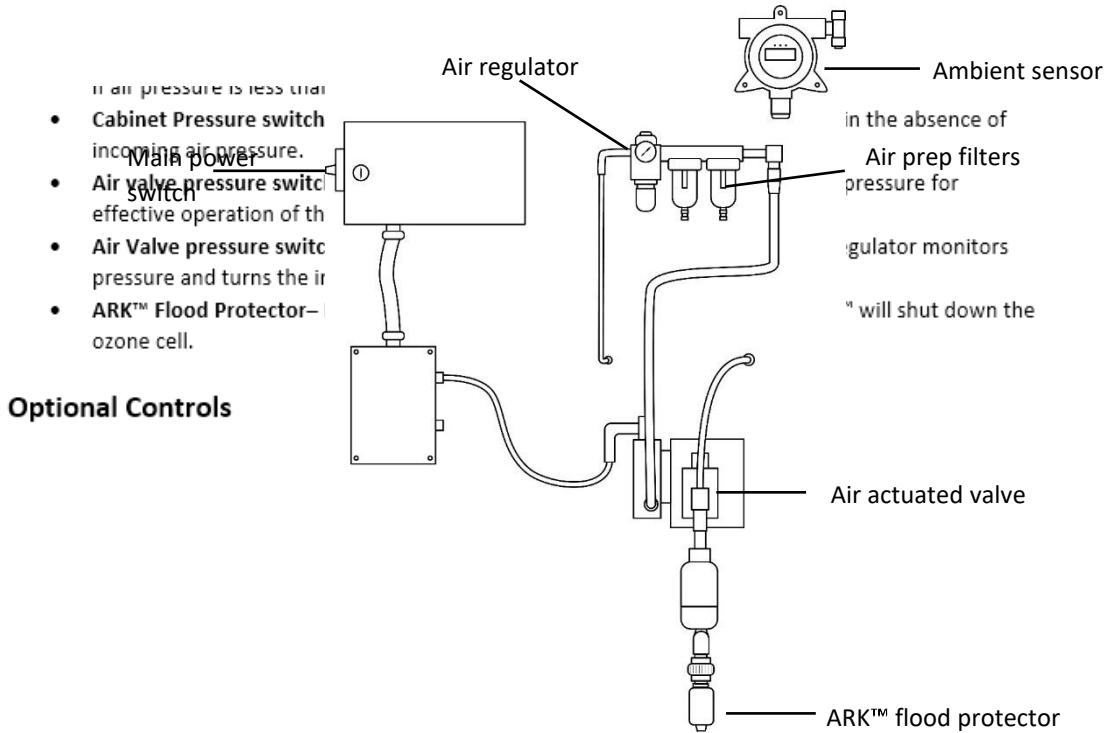

Cabinet back – S Series

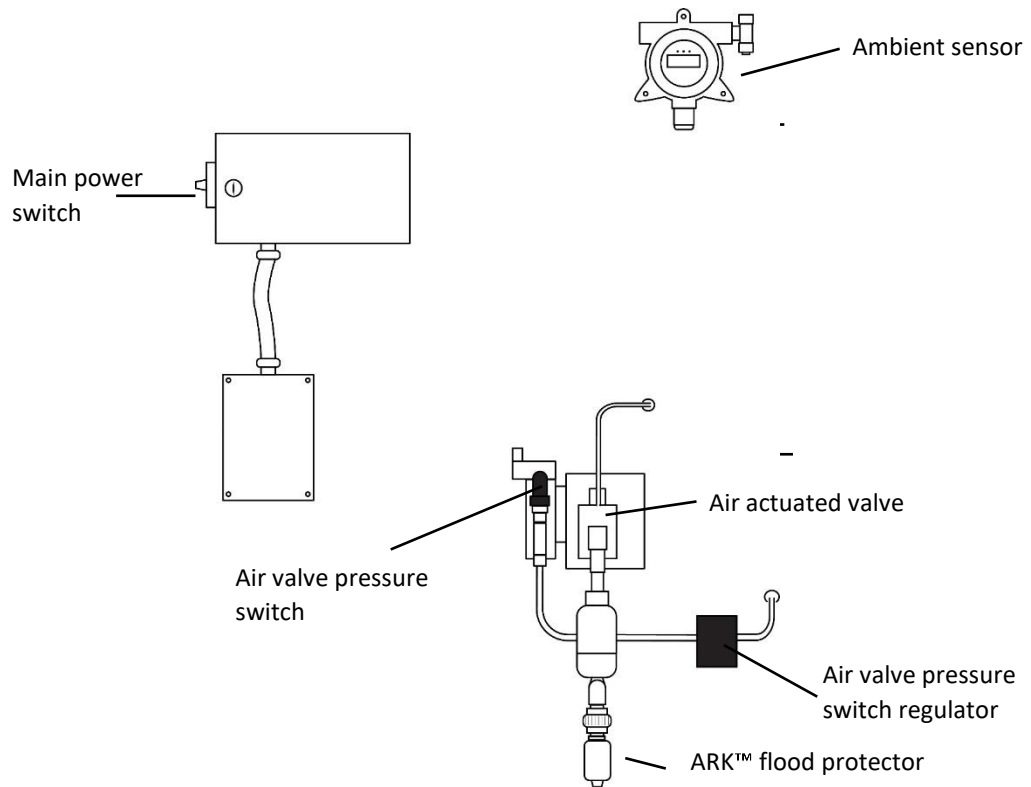

Cabinet back – SC Series

D.Safety Features and Controls

The S / SC Series have numerous safety features to both protect the user and the system itself.

Safety Features

- **Mazzei pressure sensors** – Pressure sensors both measure and monitor water pressure differential, ensuring functioning of the booster pump.
- **Ambient ozone monitor(s)** – The cabinet has an exterior ozone monitor which detects small leaks of ambient ozone in and around the unit. The unit will shut off and resume once there is no ozone detected. The S / SC Series have the capacity to receive input from a second remote sensor.
- **Check valve** – A check valve on the inlet of the Mazzei protects the ozone cell from pressurized water.
- **Air actuated valve** – This valve closes automatically when the pump is turned off to prevent backflow of water into the ozone unit in case of check valve failure. It will also close automatically if air pressure is less than 80psi.
- **Cabinet Pressure switch** – The cabinet pressure switch protects the ozone cell in the absence of incoming air pressure.
- **Air valve pressure switch** – The air valve pressure switch ensures sufficient air pressure for effective operation of the air valve.
- **Air Valve pressure switch regulator (SC only)** – The air valve pressure switch regulator monitors pressure and turns the internal air valve compressor on and off.
- **ARK™ Flood Protector**– In case of check valve failure, the ARK Flood Protector™ will shut down the ozone cell.

Optional Controls

- **MODBUS** – The S / SC Series are Modbus TCP capable.

Gauges

General guidelines unless otherwise specified by Purifico Ozone Inc.

- Incoming pressure gauge (0 to 150 psi)
- Booster pump pressure gauge (0 to 150 psi) – A pressure differential of 30 to 50psi should be maintained.
- Oxygen pressure gauge (0 to 30psi) – The ozone cell requires an incoming oxygen positive pressure of 15 to 20psi.
- Ozone vacuum gauge (-30 to 30psi) - Vacuum pressure should be -5 to +15psi.

ORP Sensor

The ORP sensor is responsible for turning the ozone cell on and off based on ORP setpoints. There are three main components to maintenance of ORP probes: Probe cleaning, replacing reference solution, and replacing the salt bridge.

Calibration

see page 27

Probe Cleaning

The probe should be kept reasonably clean to avoid measurement errors. Frequency of cleaning required will depend on water quality. To clean, proceed as follows:

***Be careful when using a toothbrush: The process electrode of a pH probe is comprised of very thin glass and breaks easily. Breaking it is the death of the probe.*

1. Rinse the probe and use a soft brush, e.g. a soft toothbrush, and detergent to gently remove loose debris.
2. Rinse with clean warm water. Tap water is fine.
3. For scaling (calcium carbonate deposits) soak the probe in a weak acid for about an hour. White vinegar works great. Hydrochloric or sulfuric acid diluted ten-fold will do the job in about 10 minutes.
4. For iron deposits, soak the probe in a weak acid for about 5 minutes. Use a soft toothbrush if needed to gently remove remaining iron.
5. For biofilm fouling soak the probe in bleach for about 20 minutes.
6. Rinse the probe again in water.
7. Calibrate the probe in accordance with the instrument instruction manual

Replacement of Salt Bridge

If the ORP calibration is unsuccessful after cleaning, the reference solution and salt bridge may need to be replaced. Replacement is recommended if offset is less than -62.5mV or more than +62.5mV, or if gain is less than 75% or more than 125%.

To preserve accuracy of the ORP probe, the internal salt bridge should always be replaced on a 6 month to one year schedule. Once a year is recommended for water that is relatively clean, and twice a year if the water has a high EC or has high organic content level. Test ORP against a standard solution to confirm calibration. To change the salt bridge, proceed as follows:

1. Use a hex driver to remove and install the salt bridge.
2. Hold the probe vertically with electrodes up. Remove the used salt bridge.
3. Discard the used salt bridge.
4. Dispose of the used solution inside the bridge chamber and flush with pH7 solution or distilled water.

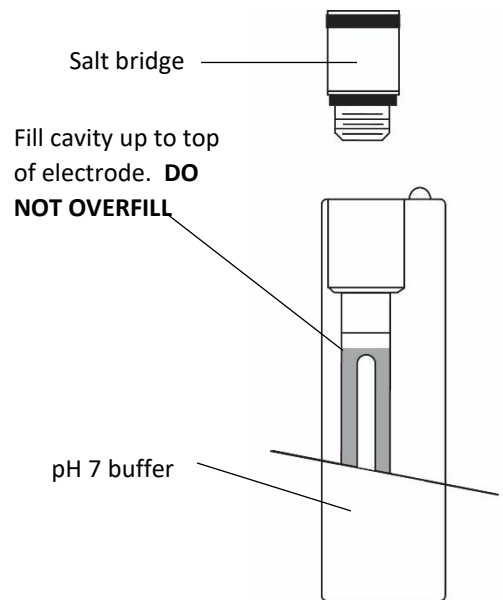

5. Refill the chamber with pH7 buffer solution, up to the tip of the electrode, inside the chamber. **DO NOT OVERFILL.**
It is important to leave space for the salt bridge thread and a small amount of air.
6. Screw the new salt bridge into the cavity until finger tight. Now perform a ¼ turn with a 9/16" socket wrench. The salt bridge edges should be flush with the front of the probe face.

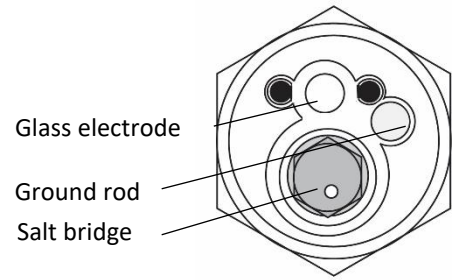

Storage

If the sensor is removed from the process for an extended period, thoroughly clean the sensor, put a piece of cotton ball with a few drops of water into the protective cap and replace it on the sensor. This keeps the junction from drying out which causes slow response when put back into operation or causes permanent damage to the sensor. **Sensors should not be left in dry lines or empty tanks for extended periods.**

Do not store the sensors in a dry or humid location. When storing, check the protective cap(s) regularly to make sure the cotton ball remains moist. Improper storage of sensors voids the warranty

Mazzei Pressure Sensors

Two pressure sensors, measuring water flow pressure before and after the booster pump, calculate whether there is sufficient pressure differential to create the vacuum necessary for optimal operation of the Mazzei venturi injection nozzle.

ARK™ Flood Sensor

All S / SC Series ozone systems are equipped with the proprietary ARK™ Flood Sensor, which will automatically turn off the ozone cell if the ARK™ is in contact with water. A fault from the ARK™ would be indicated on the home screen by a red Flood Sensor indicator and must be manually restarted by an operator selecting the **Sensors RESET** on the home screen.

The sensor should NOT be reset until the reason for the fault has been identified and rectified.

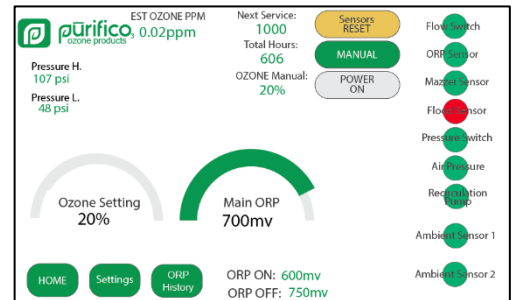

Ambient Ozone Monitor

Your ozone leak gas detector will detect ozone gas at 0.1 ppm and has been pre-set to sound an alarm at 1.0ppm (ALARM1) and to turn the system off at 0.3ppm (ALARM2). These settings may be adjusted by the customer with the remote. Note that if precision settings are changed, range, first alarm and second alarm must be reset. To preserve accuracy, the sensor should be calibrated every 6 months, and the internal gas sensor should be replaced every 2 years. Bump testing should be performed based on local safety guidelines. Note that this detector is intended to protect the ozone system from leaks and is not intended to be relied on for life safety purposes.

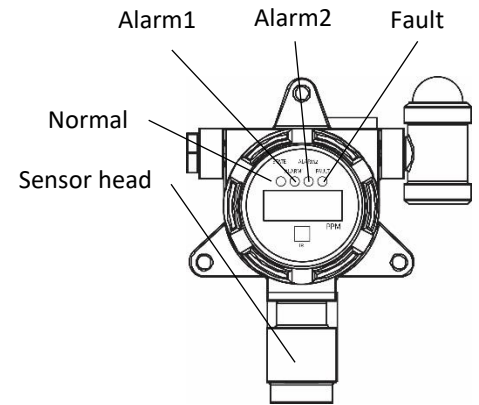

Air Prep System

The ozone generating cell requires a source of clean, dry, high-oxygen content air in order to efficiency produce ozone, making the air prep system an integral part of the S / SC Series.

S Series – requires hook up to compressed air

SC Series – air compressor on board

Air flow meter

Air flow should be maintained at 6-10 Lpm (40/80gph systems) and 15-20 Lpm (160gph systems).

Oxygen pressure gauge (top cabinet)

The ozone cell requires an incoming oxygen positive pressure of 10-20psi.

Desiccant dryer

The desiccant dryer ensures that concentrated oxygen going into the ozone cell is dry. When the sight glass changes colour, the desiccant must be changed. Contact your Purifico Ozone Inc. rep for details.

E. Operations

The S / SC Series have a user-friendly HMI screen to provide complete system monitoring and control. This allows customization of the ozone unit output to meet required specifications of the system, while monitoring and protecting the unit and surroundings through a range of system and environmental safety features.

HOME screen – manual mode – ozone on

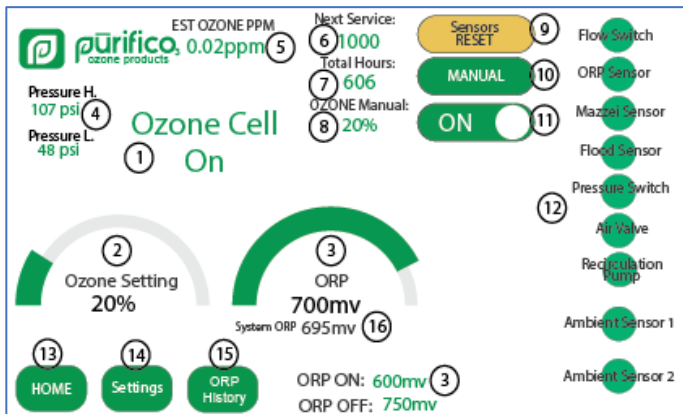

HOME screen – auto mode – standby

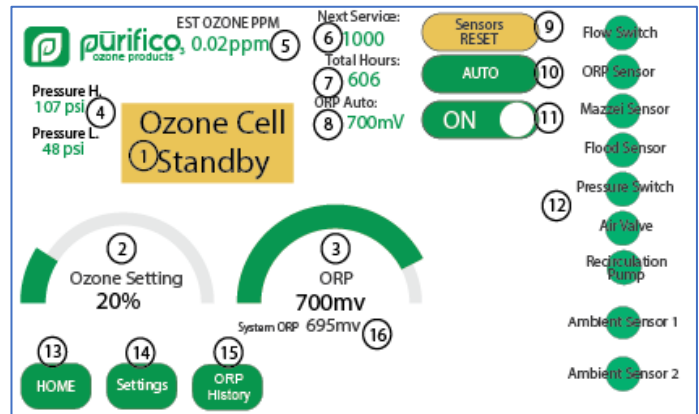

Home Screen Features

- ① Ozone cell status
 - Ozone Cell On – ozone required, all safety requirements met, cell running
 - Ozone Cell Standby – ozone not required, all safety requirements met, cell ready
 - No indicator – ozone not required OR safety requirement(s) unmet
- ② Ozone Setting
 - Manual mode – indicator will show set value of ozone cell output
 - Auto mode – indicator will show ozone cell output required to match ORP required
- ③ ORP reading
 - Manual/Auto modes – ORP reading in millivolts (mV)
 - Manual mode - ORP ON and ORP OFF settings will also be shown
- ④ Mazzei pressor sensor readings
 - PSI readings of water pressure before and after booster pump
- ⑤ Estimated ozone ppm - based on ORP reading
- ⑥ Next Service – hours at which next service is required
- ⑦ Total Hours
- ⑧ Ozone output setting
 - Automatic mode will display “ORP auto” and set mV value
 - Manual mode will display “OZONE manual” and set cell output value
- ⑨ Sensor reset button – select to reset sensors after fault

- ⑩ Operating mode indicator – will indicate either AUTOMATIC or MANUAL – (see page 21)
Operating mode can be changed from either the Home screen, Auto mode screen, or Manual mode screen
- ⑪ System power status – turn system on and off
- ⑫ Sensor/switch indicators
If a sensor/switch has been put on bypass, the indicator will not show on the Home screen.
Note that sensors/switches should only be bypassed for short periods of time by a qualified technician during testing or repairs.
- Primary Indicators
- Flow Switch** –Green indicates that there is flow and the ozone unit is on. Yellow indicates there is no flow and the ozone unit is in standby.
- ORP Sensor** – Green indicates that the ORP is equal or greater than set ORP. Yellow indicates that the ORP demand is satisfied.
- Manual mode - The indicator will be yellow when the ORP reading is higher than the set “ORP off” value
- Automatic – The indicator will be yellow when the ORP reading is higher than the set “ORP Auto” value
- Mazzei Sensor** – Green indicates sufficient water flow pressure differential. Red indicates a fault.
- Secondary Indicators. Green indicates normal operation. Red indicates a fault.
- Flood Sensor** – third layer of protection from check valve and air valve failure
- Pressure switch** – ensures sufficient oxygen pressure going into the ozone cell, protecting the ozone cell from damage
- Air Valve** – air valve pressure switch ensures sufficient air pressure to operate the safety air valve
- Ambient sensor(s)**– monitors air surrounding the unit for protection from leaks
- ⑬ Home icon – return to this home screen from any other screen
- ⑭ Settings – access additional settings
- ⑮ ORP History – see history of ORP
- ⑯ Secondary ORP sensor (optional)
Manual/Auto modes – ORP reading of second ORP sensor in millivolts (mV)

Settings Overview

Language selection – Select English, French, and Spanish as required.

Settings

Auto Mode – select Auto mode and set parameters

Manual Mode – select Manual mode and set parameters

Mazzei Sensor – set pressure range, gain, offset, vacuum, time delay

Ambient Sensor – select auto/manual restart after fault parameters; reset after fault

Time Off Delay – set delays on concentrator and air valve to allow purging of ozone cell

Recirculation Pump – set time off delay and acceleration time of recirculation pump

Est Ozone ppm – estimate correlation between Ozone ppm with ORP readings

Management

Bypass Sensors – select sensors to temporarily bypass

Ozone Cell Reset – reset ozone cell after a fault

Water Quality Alerts – set high and low ORP alerts

Backup/Restore – backup or restore system data

ORP Calibrate – to calibrating ORP probe

Oxygen Mode – turn oxygen mode on/off, select settings

Information

System Info – see specific information about the system

Alarm Log – to view log of alarms

Date/Time – set system date and time

Service Hours – for technician to reset hour counter after service

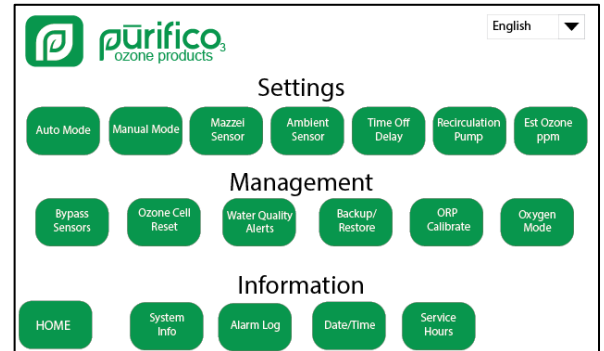

Password Protection

Some settings are password protected. When prompted, enter **User name** and **Password**.

Modes of Operation

The Purifico Ozone Inc. S / SC Series can operate in either Automatic or Manual operating mode. Mode can be selected directly from the home screen, or through settings (Auto Mode or Manual Mode icons).

Automatic

In automatic mode, the ozone output is controlled by the ORP reading. When there is flow, the ozone output (%) will automatically adjust to maintain the water at the desired ORP reading.

Manual

In manual mode, the ozone output is set (%) and when there is flow, operates at that output within the set ORP ON and ORP OFF range.

Automatic Ozone Output Mode

From Home screen

1. Select **Settings** icon
2. Select **Auto mode**
3. Change from MANUAL to AUTOMATIC
4. Set **mv ORP automatic** (in mV)
5. PI controller settings (if required)
Set Gain (range 0-99)
Set Integral Time: (range 1-6000sec)

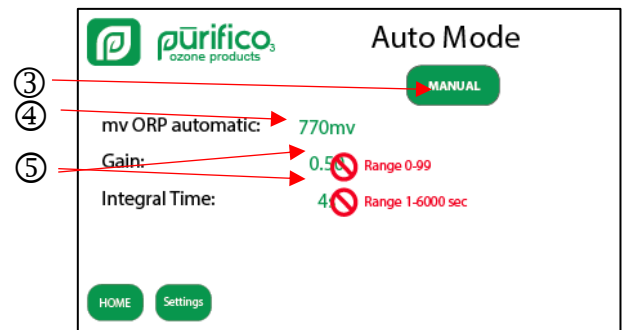

Manual Ozone Output Mode

From Home screen,

1. Select **Settings** icon
2. Select **Manual mode**
3. Change from AUTOMATIC TO MANUAL
4. Set **% OZONE manual** value
5. Set **ORP ON** value – value (mV) at which ozone cell will turn on
6. Set **ORP OFF** value- ORP reading at which ozone cell will turn off.

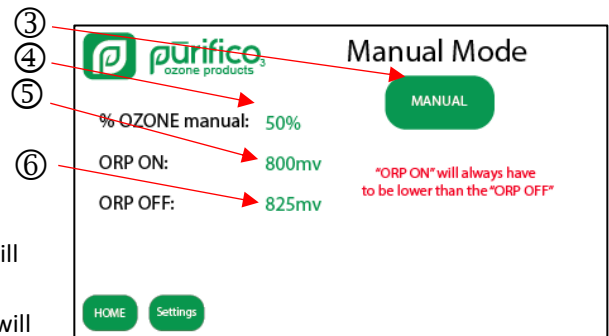

Mazzei Sensor

From the home screen,

1. Select **Settings** icon
2. Select **Mazzei Sensor** icon
3. **Pressure H** – reads high pressure gauge
4. **Pressure L** – reads low pressure gauge
5. **Gain**- set Gain values to match installed pressure sensors
 - a. 0-200psi: gain of 0.20
 - b. 0-100psi: gain of 0.10
6. **Offset** – to be set by Purifico Ozone Inc. technician
7. **Pressure differential** – factory setting 30 - 40psi
8. **Time delay for Mazzei** – sets delay on Mazzei sensor fault, allowing time for water pressure differential to develop on system start up – factory default 5 seconds
9. **Time delay for pressure** – sets delay on pressure switch fault, allowing time for oxygen pressure to develop on system start up – factory default 5 seconds

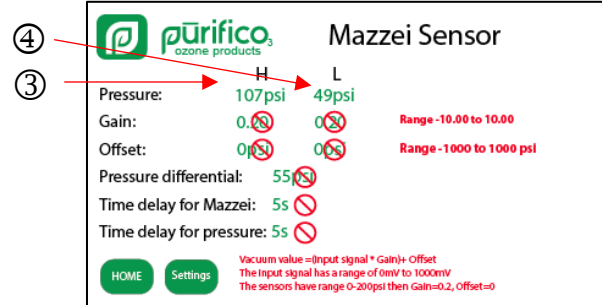

Ambient Sensor(s)

The S / SC Series are equipped with an ambient sensor to detect ozone around the unit. A secondary sensor can be additionally connected in parallel if desired. If ambient ozone is detected, the ozone system will shut down until the sensor no longer detects ozone and will be shown on the home screen by a red indicator.

The system can be set to either require a manual reset before restarting, or to resume operations after the "Turn On Automatically After" time setting has been satisfied. By default, the system requires a manual restart, and is password protected to change this option.

When ambient ozone is detected due to a leak, the system will be shut down and the home screen indicator will be red. If the system is in manual reset mode, the operator will have to select **Sensors RESET** to turn the system back on. It can also be reset from the Ambient Sensor screen.

If the Automatic Restart is set to ON, once the sensor no longer detects ambient ozone, the count down will be shown and when completed, the indicator will return to green, and the system will turn back on.

Automatic Restart

From Home screen

1. Select **Settings** icon
2. Select **Ambient Sensor** icon
3. Toggle the **Automatically Restart On** button to the **ON** position.
4. Set **Turn on Automatically After** to desired reset time. This is the delay before restarting once the sensor no longer detects ozone.

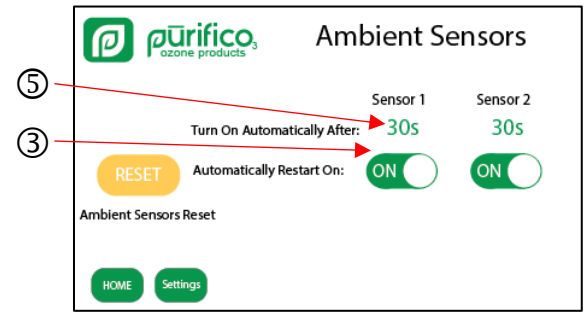

Manual Restart

From Home screen

1. Select **Settings** icon
2. Select **Ambient Sensor** icon
3. Toggle the **Automatically Restart On** button to the **OFF** position

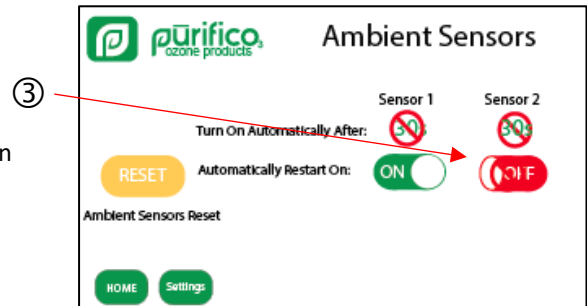

Time Off Delay

To purge the ozone cell and leave it without ozone or gas pressure, a delay in shutting down both the concentrator followed by the air valve should be set. Once the ozone cell goes into standby mode, the count-down for the oxygen concentrator will begin. Once the oxygen concentrator shuts down, the countdown for the air valve will begin. When the air valve closes, the countdown for the booster pump will begin.

From the home screen,

1. Select **Settings** icon
2. Select **Time Off Delay** icon
3. Select **Time Off Delay Oxygen Concentrator** time delay for concentrator
4. Set **Time Off Delay Air Valve** time delay for air valve.
5. Set **Time Off Delay Booster Pump** time delay for booster pump.

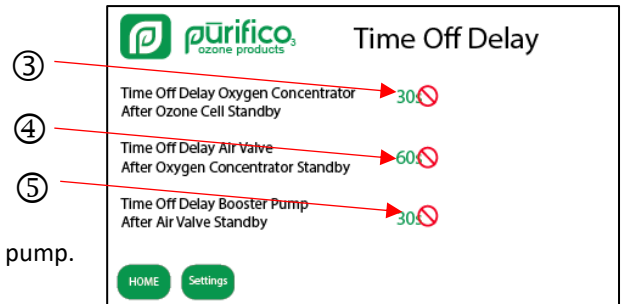

Recirculation Pump

The Purifico Ozone Inc. S / SC Series have the option of having the ozone system control the external recirculation pump.

1. Select **Settings** icon
2. Select **Recirculation Pump** icon
3. Select **Time Off Delay** – set duration of time between shutting down of ozone cell and turning off of recirculation pump
4. Select **Acceleration Time** – set duration of delay between pump start up and flow switch sensor. This allows time for the recirculation pump to develop flow before the Flow Sensor would fault.
5. **Bypass** – toggle to OFF if recirculation pump is not to be controlled by the ozone system. Indicator will not show on the home screen.

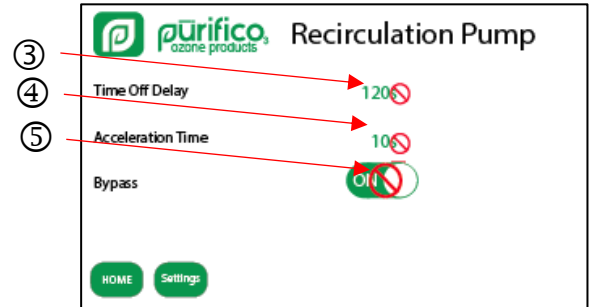

Est Ozone ppm

The estimated ozone ppm in treated water can be calculated by correlating ORP readings with testing of ozone ppm.

From Home screen

1. Select **Settings** icon
2. Select **Est Ozone ppm** icon
3. Enter ppm values next to corresponding ORP
4. Estimated ORP will be shown on the home screen

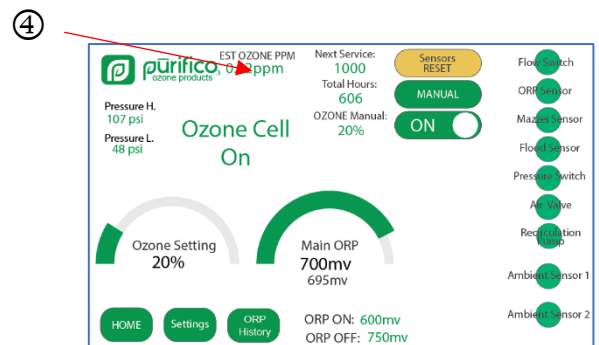
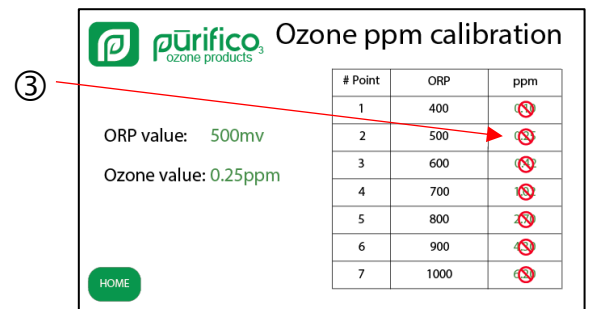

Bypass Sensors

Sensors are controls that provide functionality and safety. They should only be bypassed for short periods of time by a qualified technician during testing or repairs. At no point should the unit be left unattended while sensors are bypassed.

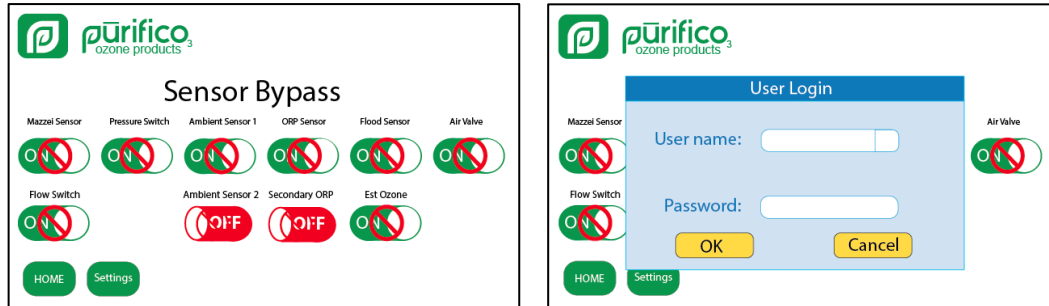

The option to bypass switches and sensors is locked by default, and password protected.

From Home screen

1. Select **Settings** icon
2. Select **Bypass Sensors**
3. Select sensor to be bypassed. Note that if there is not an optional Secondary ORP or Ambient Sensor 2 with the system, the toggles will be in the OFF position.
4. Toggle to **OFF**

When a sensor has been put into bypass mode, the indicator will not appear on the home screen.

When testing/repairs have been completed, be sure to turn sensor(s) back on.

Ozone Cell Reset

The ozone generating cell within the unit has protective internal monitoring which will shut down the cell in the event of a fault.

Ozone Cell Reset

From Home screen

1. Select **Settings** icon
2. Select **Ozone Cell Reset**
3. Select **Reset**

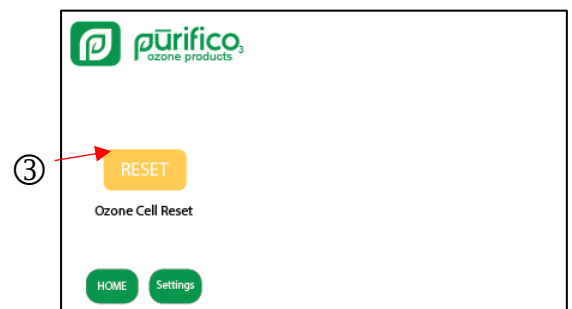

Water Quality Alerts

To be notified of either a high or low range ORP, enter values for alerts.

From Home screen

1. Select **Settings**
2. Select **Water Quality**
3. **ORP Value** – display of live ORP reading
4. Select **ORP High Limit** - set high ORP limit for alert
5. Select **ORP Lower Limit** – set low ORP limit for alert
6. To turn off alerts, select toggle switch for limit to bypass
7. Toggle switch to **OFF**

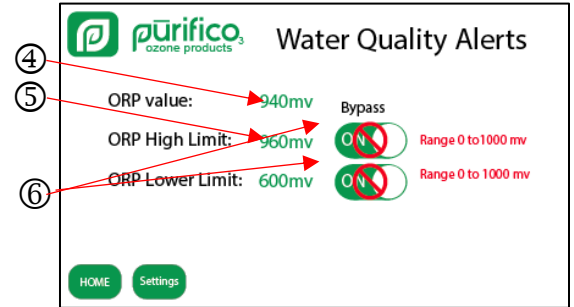

Backup/Restore

From Home screen

1. Select **Settings**
2. Select **Backup/Restore**
3. To create backup, select **Create**
4. To restore settings to backup, select **Restore**

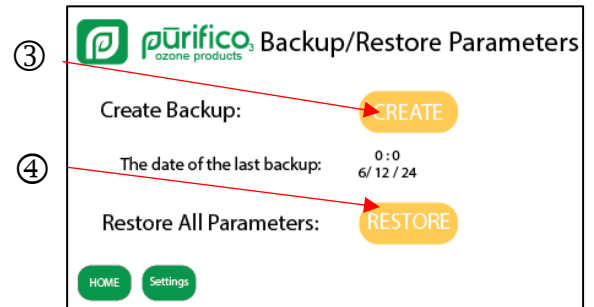

ORP Calibration

To maintain accuracy of the system, the ORP probe(s) should be calibrated frequently. Depending on the application, this can range from every two weeks to every few months. To calibrate the probe, standard 200mV and 600mV solutions are recommended. Other ORP standards may be used so long as they are intended for platinum or gold electrodes, however it is recommended to have at least a 300mV difference between the two solutions.

From the Home screen

1. Select **Settings**
2. Select **ORP Calibrate**
3. Select **Lower solution** and enter the corresponding mV value (e.g. 200mV) of the solution being used.
4. Select **Upper solution** and enter the corresponding mV value (e.g. 600mV) of the solution being used.
5. Select **Start Calibration**
6. Enter **user name** and **password**
7. When prompted, immerse probe in the lower solution (e.g. 200mv) solution then press **OK**
8. Keep the probe immersed in the solution and wait until the countdown is complete.
9. Either a fault or success will be indicated. If it faults, clean or replace the probe and repeat the calibration. If the OK button appears, proceed to the next step.
10. When prompted, immerse probe in the “high standard” (e.g. 600mv) solution. Keep the probe immersed in the solution and wait until the countdown is complete.
11. Either a fault or success will be indicated. If it faults, clean the probe and repeat the calibration. If the OK button appears, calibration is complete.
12. Repeat steps 7-11 for second probe if present.

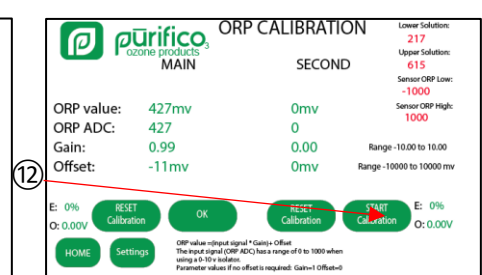
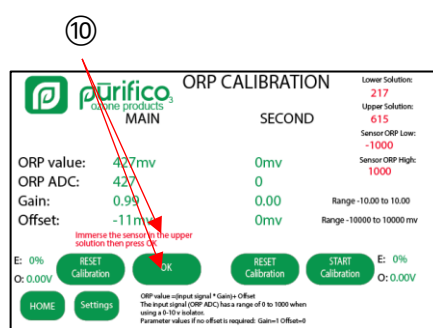
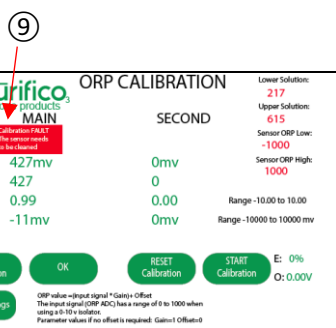
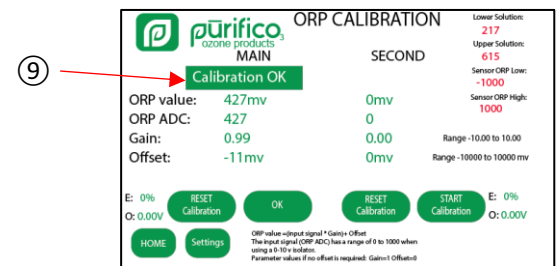
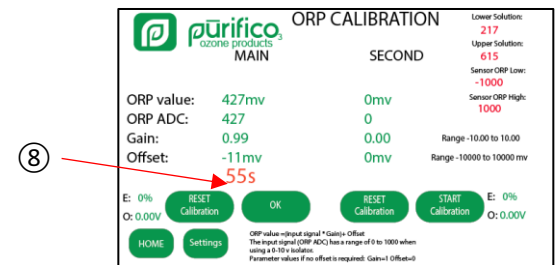
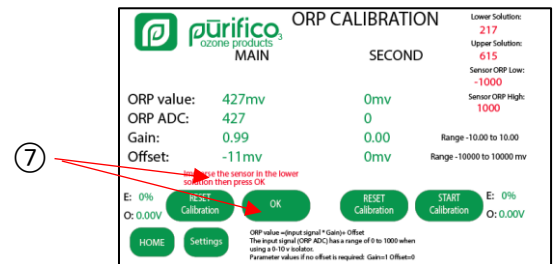
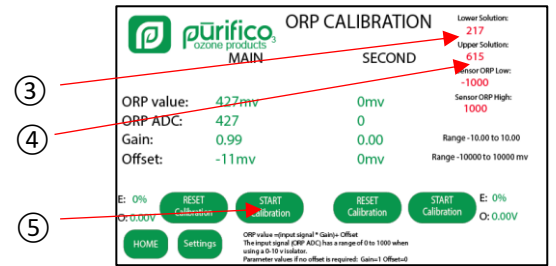

Oxygen Mode

The S/ SC Series can be set to continue to inject oxygen when the need for ozone has been met.

From Home screen

1. Select **Settings**
2. Select **Oxygen Mode**
3. Set **Time Off Delay** for duration that system should run after the ozone cell shuts off.
4. **Remaining Time** will display the time remaining until the oxygen concentrator will shut down.
5. If continuous oxygen injection is required, toggle **Activate Infinity Mode** to the ON position.

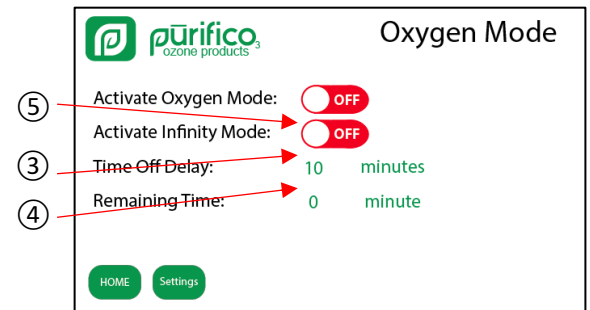

System Info

From Home screen

6. Select **Settings**
7. Select **System Info** icon
8. View system details.
9. Access online manual.

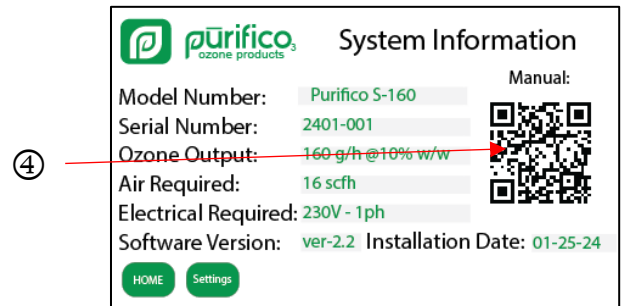

Alarm Log

From Home screen

1. Select **Settings**
2. Select **Alarm Log**
3. View history of recent faults and alerts

Time	Date	Message	Group Name
05:30	01/08/23	Board Fault ERROR	ErrorLog
13:50	05/16/23	Ambient Sensor ERROR	ErrorLog
09:45	05/08/23	Flood Sensor ERROR	ErrorLog
1:13	09/01/23	Board Fault ERROR	ErrorLog

Date/Time

Backup ORP history to USB prior to changing time or date

From the home screen,

1. Select **Settings** icon
2. Select **Date/Time** icon
3. Select **Change the date and time**
4. If desired, select **Clear History**

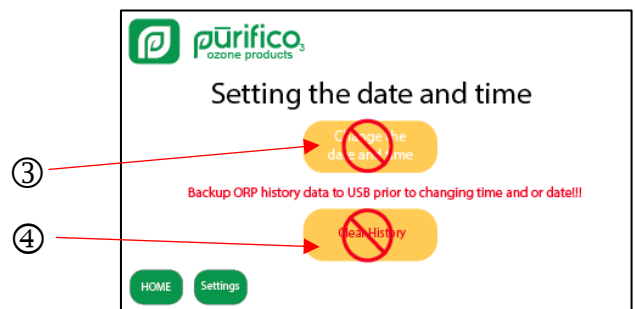

Service Hours

The S / SC Series will track operational hours and alert the user when service is due.

From Home screen

1. Select **Settings**
2. Select the **Service Hours**
3. **Service Interval** – Set system hours desired between scheduled service.
4. **Service Hour** – Tracks hours since last service. Will return to 0 on Reset.
5. **Next Service** – Calculates hours remaining before service required, based on set Service Interval. When the countdown reaches zero, an alert will be shown on the home screen.
6. **Total hours** – Tracks total hours of system.
7. When service has been completed by a qualified technician, select the **RESET** button. Note** once reset is completed it takes up to 30 seconds for screen to acknowledge update.

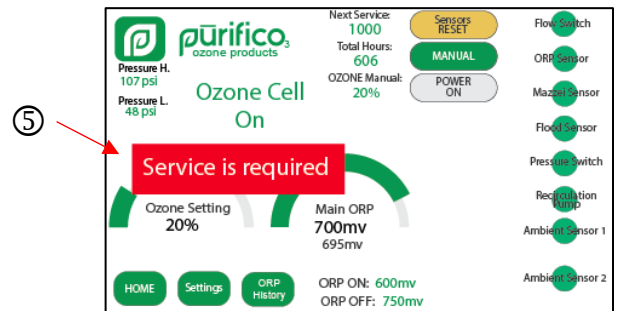
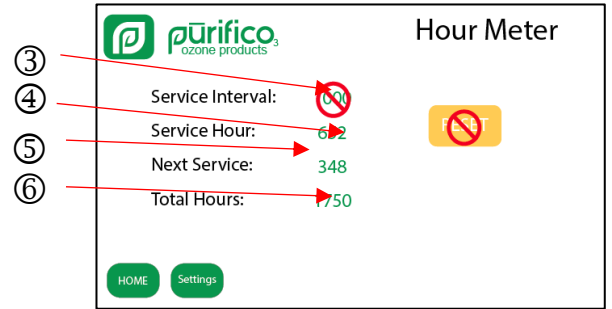

ORP History

The Purifico Ozone Inc. S / SC Series can provide a downloadable history of the ORP; the user defined timeframe allows the user to select a time period view that provides the most beneficial information for their needs.

From the Home screen

1. Select **ORP History** to view graph
2. Change year, month, day, hour and minute as required. Select **Apply**
3. **Write to USB** – insert USB into port on back of the HMI screen

To correct date/time error or adjust for daylight savings time, go to Date/Time under Settings (see page 28)

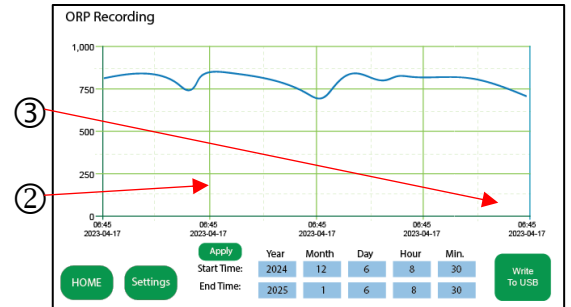

F. Plumbing options

Depending on infrastructure and water treatment requirements, the system can be plumbed into existing infrastructure as either flow-through or side stream injection.

Flow-through

To set the system up as flow through, all three (3) ball valves are set to the OPEN position.

Side-stream

To set the system up for recirculation, the second ball valve is set to the CLOSED position.

Note** Inlet and outlet is reversed when going from side-stream to flow-through.

OPEN – flow through
CLOSED – side stream

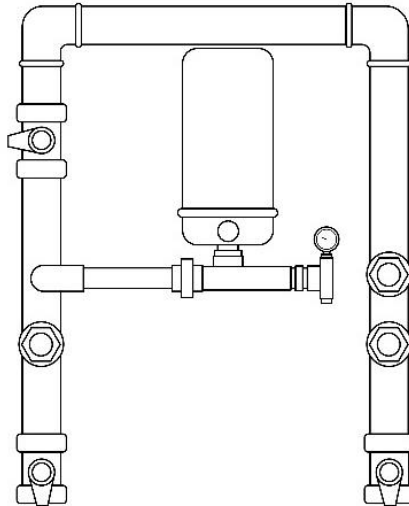

G. Maintenance

Maintenance of your ozone system is critical to its longevity and operating efficiency.

CAUTION: Observe all common safety practices and review the “Safety Information” sections before attempting any maintenance procedure that requires the use of tools and/or shutting down the ozone system.

Daily Inspection

- HMI Screen - Look at the information display to verify the system is operational and has no faults. Confirm that the unit is operating in the desired mode (automatic or manual). Address any issues.
- Check for water leaks.
- Confirm no smell of ozone.

Weekly Maintenance

- **Cabinet air filters** If filter(s) on cabinet are dirty or plugged, pull out and clean. Operating conditions in the equipment area will dictate the frequency required for this procedure.
- **O₂ flow meter** Check to ensure that it is running at an adequate volume level for your model. If you notice white powder, call your Purifico Ozone Inc. rep.
- **HMI screen** Look at the information display to verify the system is operational and has no problems. Confirm that the unit is operating in the desired mode (automatic or manual). Review service hours (will prompt when due for service).
- **Ozone delivery line** Inspect the ozone delivery lines that run from the back of the cabinet to the venturi nozzle. If water is observed in the delivery line near the check valve assembly, the check valve may have failed.
- **Exterior cooling fan(s)** Check to make sure the exterior cooling fan(s) mounted in the ozone cabinet are operating. The top cabinet one is thermostatically controlled and can be tested by turning up/down the thermostat setting.
- **Interior cabinet fan** Check to make sure the fan is running when the ozone cell is on.
- **Air prep filters (S Series only)** Drain any accumulated condensation.
- **Desiccant dryer** Inspect desiccant sight glass to confirm that desiccant does not require replacement. Sight glass will change colour when replacement is required.
- **Gas off valve (if present)** – Visually inspect to confirm bubbling.
- **ORP Sensor** – Clean on schedule determined by needs of source water. (see page 15)

Annual /semi annual maintenance

- To preserve accuracy of the ORP probe, the internal salt bridge should be replaced on a 6 month to one year schedule. Once a year is recommended for water that is relatively clean, and twice a year if the water is full of slats or organic contaminants. Test ORP against a standard solution to confirm calibration.
- Preventatively replace check valves every 6 months or as required.
- Testing and calibration of any external ambient sensors should be routinely completed.

H.Trouble Shooting

Air Preparation /Lower Cabinet

Problem / Symptom	Possible Cause	Solution(s)
Unit not operating	<ul style="list-style-type: none"> • No power to system • Power switch in OFF position 	<ul style="list-style-type: none"> • Check main power to system. • Turn switch to ON position.
Pressure switch fault	<ul style="list-style-type: none"> • Low incoming air supply • Solenoid power issue • Solenoid valve issue • Faulty pressure switch • Inline filter (if present) plugged • Faulty compressor • Leaks in air supply system • Other 	<ul style="list-style-type: none"> • Check pressure gauge on air regulator (back of system) – should be 30-45 psi • Check sieve bed solenoid power (*blue light showing on sieve bed control board) • If no blue light indicator on sieve bed control board, check power supply 2A fuse • If blue light indicator is on, check solenoid valve on concentrator sieve beds. Replace if required. • Check pressure switch. Replace if required. • Replace filter • Check compressor • Check for leaks • If confirmed that there is pressure, pressure switch may be temporarily bypassed during repairs.
Insufficient air flow	<ul style="list-style-type: none"> • Compressor failure 	<ul style="list-style-type: none"> • Repair or replace as necessary
Powder in air flow meter	<ul style="list-style-type: none"> • Sieve bed fatigue 	<ul style="list-style-type: none"> • Replace sieve bed(s). Clean out air flow meter. • May also require replacement of desiccant in air dryer.

Ozone Generator

Problem / Symptom	Possible Cause	Solution(s)
Information display not illuminating, or system is not ON	<ul style="list-style-type: none"> • No power to unit • Power switch in OFF position • Flipped breaker • Blown fuse • Faulty connection to screen • Faulty HMI screen 	<ul style="list-style-type: none"> • Check main power to system. • Turn switch to ON position. • Check cabinet main breaker. • Check breaker / fuse to 24V power supply. • Check connection to screen. • Replace screen.
24V fuse blown	<ul style="list-style-type: none"> • Fault with one of: <ul style="list-style-type: none"> • Ambient sensor(s) • Pressure switch • Vacuum switch • HMI screen • Siemens LOGO • Air valve 	<ul style="list-style-type: none"> • Replace fuse • Determine fault and address issue(s)
24V power supply breaker flips	<ul style="list-style-type: none"> • Faulty 24V power supply 	<ul style="list-style-type: none"> • Replace power supply
Mazzei sensor (pressure differential) fault	<ul style="list-style-type: none"> • Change in pressure feed to system • Mazzei blocked • Loose/broken fittings • Weak pump 	<ul style="list-style-type: none"> • Check incoming pressure gauge (top gauge) to confirm pressure • Check booster pump gauges to confirm 45-55 psi differential • Ensure that small ball valve between gauges is closed • Ensure adequate water supply • With pump running, check for suction at venturi injector • Replace venturi injector if required • Check for air leaks around fittings • Test pump. Repair or replace as required.

Problem / Symptom	Possible Cause	Solution(s)
Ambient ozone fault / ozone smell detected	<ul style="list-style-type: none"> • Ozone leak 	<ul style="list-style-type: none"> • Turn main power to ozone system off. Ventilate area. Check connections and fittings between ozone cell and venturi injector.
Fan between top and bottom of cabinet not operating	<ul style="list-style-type: none"> • Fan obstructed • Ozone cell breaker tripped • Fan inoperable 	<ul style="list-style-type: none"> • Remove obstruction • Switch breaker to ON, and monitor • Replace fan
Cabinet overheating	<ul style="list-style-type: none"> • Side mounted fan failure • Thermostat failure • Dirty filters on side vents • Cabinet interior fan failure 	<ul style="list-style-type: none"> • Check breaker. Reset as required. • Replace if required. • Test fan response to thermostat. • Replace if required. • Remove side filters, clean, and/or replace. • Repair or replace as required.
Ozone cell fault	<ul style="list-style-type: none"> • Damaged board • Flooded cell 	<ul style="list-style-type: none"> • Reset board. If problem persists, call Purifico Ozone Inc. rep. • If known to have water damage, call Purifico rep. Shut water off to system, and release pressure.
Water in line between check valve and cabinet	<ul style="list-style-type: none"> • Defective check valve 	<ul style="list-style-type: none"> • Replace check valve

I. Responsibility Disclaimer

Purifico Ozone Inc. provides ozone water treatment solutions intended for agricultural applications. The user is responsible for water quality monitoring and equipment maintenance. It is the user's responsibility to comply with all applicable laws and regulations. While Purifico Ozone Inc. Inc. provides information in good faith, we make no claims regarding its comprehensiveness or accuracy.

Purifico Ozone Inc. is not responsible for the choice, installation, maintenance, or operation of safety equipment, sensors for monitoring, or alarm systems, whether for safeguarding personnel, property, environment, or any other purpose. Under no circumstances will Purifico Ozone Inc. be liable for any lost profits or for direct, indirect, incidental, special, or consequential damages of any kind.

Purifico Ozone Inc. accepts responsibility for the reliability and performance of this equipment only under the following conditions:

- Any modifications to the equipment are authorized in writing by Purifico Ozone Inc. and carried out by an authorized service technician.
- The ambient conditions for the equipment, including but not limited to temperature, humidity, air quality, vibrations, or shock, meet the requirements set by Purifico Ozone Inc. during both operation and stand-still.
- The supply of all deliverables, including but not limited to air, oxygen, and electric current, complies with the requirements of this manual at all times, during both operation and stand-still.
- The electrical installation powering the equipment complies with all applicable local electrical codes and requirements, including, if applicable, IEC requirements.
- The physical installation, including but not limited to the choice of materials, piping system layout, components and connections, sensors, actuators, or back-flow prevention, follows our recommendations.
- The equipment is operated in accordance with its manuals.

Note: Temperature has a strong effect on the solubility of ozone in water. Warm incoming water will decrease the solubility of ozone and must be considered when determining the amount of ozone required for treatment.

Environmental Requirements:

- Surrounding air Relative humidity: 5 to 90%, non-condensing.
- Surrounding air ambient operating temperature: 0° to 40° C (32° to 104° F)
- No heat inducing stray fields are to be present within 3 feet (1 M) of the unit. These fields can radiate from large motors or large power supplies in the KW range.
- Altitude (maximum): 3,310 ft (1,000 m), de-rating for altitude is 1% for every 300 ft (100m) above 3000 ft (1000m).

Appendix A - Safety Data Sheet

Ozone

01 - Product Identification

Product Name: Ozone

Common Names / Synonyms: Triatomic Oxygen, Trioxygen, O₃

Ozone Generator Supplier

Farm Water Systems
9409 45 Ave Edmonton, AB
T6E 6B9
www.farmwatersystems.com

Product Use: This SDS is limited to ozone produced in gaseous form on site by an ozone generator, in varying concentrations in either air or aqueous solution, for the purposes of odor abatement, oxidation of organic compounds, or antimicrobial intervention, in treating drinking water for livestock.

24-Hour Emergency Phone: 780-999-1906

02 - Hazard Identification



GHS Classifications

Physical Hazards	Health Hazards	Environmental Hazards
Oxidizing Gas	Skin irritation – Category 3	Acute Aquatic Toxicity – Category 1
	Eye irritation – Category 2B	
	Respiratory System Toxicity – Category 1 (Acute & Repeated Exposures)	

NOTE: Severe respiratory toxicity will develop before skin or eye irritation go beyond listed categories. Anyone with chronic pulmonary problems, especially asthma, should avoid exposure to ozone.

03 - Composition

Chemical Name Triatomic oxygen, trioxygen

Common Names Ozone

Chemical Formula O₃

04 – First Aid Measures

For severe cases, or when symptoms do not improve, seek medical help.

Route of Entry	Possibility	Symptoms	First Aid
Skin contact	Yes	Irritation	Rinse with water
Skin absorption	No	NA	NA
Eye contact	Yes	Irritation	Rinse with water, remove contacts
Ingestion	No	NA	NA
Inhalation	Yes	Headache, cough, dry throat, heavy chest, shortness of breath	Remove to fresh air, provide oxygen therapy as needed

05 – Fire Fighting Measures

While ozone itself is not flammable, it is a strong oxidant and may accelerate, even initiate, combustion or cause explosions. Use whatever extinguishing agents are indicated for burning materials.

Fire prevention: No open flames. No sparks, no smoking. No contact with combustible substances.

06 – Accidental Release Measures

Turn off ozone generator and ventilate the area. Evacuate the area until ozone levels subside.

07 – Handling and Storage

Ozone must be contained within ozone-resistant tubing and pipes from the generation point to the application point. Any leaks must be repaired before further use.

08 – Exposure Controls and Personal Protection

OSHS Permissible Exposure Limit- 8-hour Time Weighted Average (TWA) **0.1 ppm**

NIOSH: Exposure Limit ceiling value **0.1 ppm** light work; **0.08 ppm** moderate work; **0.05 ppm** heavy work

Light, moderate, heavy work TWA – 2 hours, **0.2 ppm**

Immediately dangerous to life or health **5 ppm**

Toxic Effects of Ozone		
Ozone Concentration (ppm)	Duration of exposure	Effect
0.01	-	Odour threshold
0.1	-	Minor eye, nose and throat irritation
0.10-0.25	2-5 hours	Headache, dry cough and some reduction in lung function
0.3	2 hours	Reduction in lung function during moderate work for all persons
>0.6	2 hours	Chest pain
1	1-2 hours	Lung irritation (coughing); severe fatigue
>1.5	2 hours	Reduced ability to think clearly; continuing cough and extreme fatigue may last for two weeks; severe lung irritation and pulmonary edema (fluid buildup)
9	Intermittent	Severe pneumonia (arc welders)
11	15 minutes	Rapid unconsciousness
50	30 minutes	Expected to be fatal

Respiratory protection: Use full face self-contained breathing apparatus for entering areas with high concentrations of ozone.

Engineering controls: Use ozone destruct units (thermal and/or catalytic) for off gassing ozone

09 – Physical and Chemical Properties

10 – Stability and Reactivity

Physical State	Gas	pH	NA
Molecular Weight	48.0	Flash point	NA
Appearance	Clear at low concentrations, blue at higher concentrations	Evaporation rate	NA
Odor	Distinctive pungent odor	Flammability	NA
Odor threshold	0.02 to 0.05 ppm; exposure desensitizes	Explosive limits	NA
Melting point	-193°C/-315°F	Relative density	NA
Boiling point	-112°C/-169°F	Partition coefficient	NA
Vapour pressure	>1 atm	Auto-ignition temperature	NA
Vapour density	1.6 (air = 1)	Decomposition temperature	NA
Solubility in water	570 mg/L @ 20°C, 100% O ₃ , 0.64 @ 0°C (vol/vol)	Viscosity	NA

Ozone is highly unstable and highly reactive. Avoid contact with oxidizable substances, including alkenes, benzene and other aromatic compounds, rubber, dicyanogen, bromine diethyl ether, dinitrogen tetroxide, nitrogen trichloride, hydrogen bromide, and tetraluorohydrazine. Ozone will readily react and spontaneously decompose under normal ambient temperatures.

11 – Toxicological Information

Likely routes of exposure: inhalation, eyes, skin exposure

Effects of Acute Exposure: discomfort, including headache, coughing, dry throat, shortness of breath, heavy feeling in chest (including possible pulmonary edema/fluid in the lungs); higher levels of exposure intensify symptoms. Irritation of skin and / or eyes is also possible.

Effects of Chronic Exposure: Similar to acute exposure effects, with possible development of chronic breathing disorder, including asthma.

Irritancy of ozone	Yes
Sensitization to Ozone	No
Carcinogenicity (NTP, IARC, OSHA)	No
Reproductive toxicity	Not proven
Teratogenicity	Not proven
Mutagenicity	Not proven
Toxicologically Synergistic Products	Increase susceptibility to allergens, pathogen, irritants

12 – Ecological Information

The immediate surrounding area may be adversely affected by an ozone release, particularly plant life. Discharge of ozone in water solution would also be harmful to any aquatic life. Due to natural decomposition, bioaccumulation will not occur, and the area affected would be limited.

13 – Disposal Considerations

Off-gassing of ozone should be through an ozone destruct unit which uses heat and/or a catalyst to accomplish the breakdown of ozone to oxygen before release into the atmosphere.

14 – Transport Information

Ozone is produced and used on site, not meant to be transported.

15 – Regulatory Information

This substance is not specified on the DSL or NDSL. There is no control measure imposed to this substance.

16 – Other Information

Disclaimer: Purifico Ozone Inc. provides this information in good faith but makes no claim as to its comprehensiveness or accuracy. It is intended solely as a guide for the safe handling of the product by properly trained personnel, and makes no representations or warranties, express or implied of, and Purifico Ozone Inc. will not be responsible for any damages resulting from the use of, or reliance upon, this information. The responsibility to provide a safe workplace remains with the user. The user should consider the health hazards and safety information contained herein as a guide and should take those precautions required in an individual operation to instruct employees and develop work practice procedures for a safe work environment. It is the responsibility of the user to comply with all applicable laws and regulations.

References

<http://www.cdc.gov/niosh/ipcsneng/neng0068.html>

<http://www.ozoneapplications.com/info/Ozone%20Solutions%20MSDS%20Ozone.pdf>

http://www.worksafefbc.com/publications/health_and_safety/by_topic/assets/pdf/ozone_bk47.pdf

<https://pubchem.ncbi.nlm.nih.gov/compound/ozone#section=Fire-Prevention>

<https://cameochemicals.noaa.gov/chemical/5102>

http://www.ec.gc.ca/lcpe-cepa/eng/substance/chemicals_polymers.cfm

Appendix B – Potable Water Guidelines

Purifico Ozone Inc.'s water treatment systems are renowned for producing some of the cleanest and purest water across various applications. Purifico Ozone Inc. systems are not specifically designed for potable water treatment, we provide the following cautionary information to ensure our clients are well-informed. By following these guidelines and understanding the risks associated with chlorine and bromide in water treatment, clients can ensure safe and effective use of Purifico Ozone Inc. systems while adhering to health and regulatory standards.

Chlorine Requirements

Chlorine is widely used in water treatment but has several drawbacks compared to ozone, including the production of many unwanted by-products, an unpleasant taste, and residuals in the water. Health Canada's guidelines require free chlorine levels to be maintained between 0.2-4 mg/L (ppm) in water distribution systems, and not to exceed 5 mg/L (ppm). In Canada, regulating residual chlorine levels in potable water is a shared responsibility between federal and provincial/territorial governments. End users should refer to regionally applicable regulations to ensure compliance.

Bromide Concentrations

Bromide is a naturally occurring ion that is not highly toxic on its own. However, when ozone or chlorine are used to treat water containing bromide, potentially harmful disinfection byproducts (DBPs) can form. In ozone water treatment, bromide can react to form bromate (BrO_3^-). Health Canada's "Guidelines for Canadian Drinking Water Quality" set the maximum acceptable concentration (MAC) for bromate at 0.01 mg/L (10 ppb).

To minimize the formation of bromate, the presence of bromide in source water must be carefully managed. It is recommended to keep bromide levels as low as possible when using ozone for potable water treatment. Bromide concentrations below 50 $\mu\text{g/L}$ (50 ppb) are generally considered to pose a lower risk of significant bromate formation. Various factors influence bromate formation through ozonation, so it is important to evaluate each situation on a case-by-case basis.

Appendix C - Limited Warranty

The limited warranty set forth below applies to products manufactured by Purifico Ozone Inc. , located at 9409 – 45 Ave, Edmonton, Alberta, T6E-6B9, Canada, and sold by Purifico Ozone Inc. and its authorized dealers. This limited warranty is provided solely to the first retail purchaser of these products and is non-transferable to any subsequent owners or purchasers.

Purifico Ozone Inc. warrants that it will repair or replace, at its discretion, any part of the products proven to be defective in materials or workmanship within one (1) year from the date of the original purchase. Parts are covered under this warranty only when required operating conditions and procedures, as described in the manual, are adhered to.

This warranty specifically excludes any components not manufactured by Purifico Ozone Inc. that are external to the products covered, such as pumps, air compressors, monitors, tanks, or related components. Purifico Ozone Inc. will assist with warranty claims for such components purchased through Purifico Ozone Inc. , limited to the extent of the manufacturer's standard warranty.

Any repair or replacement will be warranted only for the balance of the original one (1) year warranty period.

EXCEPT FOR THE WARRANTY SET FORTH IN THIS OPERATION AND SAFETY MANUAL, THE SELLER MAKES NO CONDITION OR WARRANTY WHATSOEVER WITH RESPECT TO THE GOODS, INCLUDING ANY (a) CONDITION OR WARRANTY OF MERCHANTABILITY; (b) CONDITION OR WARRANTY OF FITNESS FOR A PARTICULAR PURPOSE; (c) CONDITION OR WARRANTY OF TITLE; (d) WARRANTY AGAINST INFRINGEMENT OF INTELLECTUAL PROPERTY RIGHTS OF A THIRD PARTY; WHETHER EXPRESS OR IMPLIED BY LAW, COURSE OF DEALING, COURSE OF PERFORMANCE, USAGE OF TRADE OR OTHERWISE.

The Seller shall not be liable for a breach of the warranty set forth in this Operation and Safety Manual unless: (i) Buyer gives written notice of the defect, reasonably described, to Seller within thirty (30) days of the time when Buyer discovers or ought to have discovered the defect; (ii) Seller is given a reasonable opportunity after receiving the notice to examine such Goods and Buyer (if requested to do so by Seller) returns such Goods to Seller's place of business at Seller's cost for the examination to take place there; and (iii) Seller reasonably verifies Buyer's claim that the Goods are defective.

The Seller shall not be liable for a breach of the warranty set forth in this Operation and Safety Manual if: (i) Buyer makes any further use of such Goods after giving such notice; (ii) the defect arises because Buyer failed to follow Seller's oral or written instructions as to the storage, installation, commissioning, use or maintenance of the Goods; or (iii) Buyer alters or repairs such Goods without the prior written consent of Seller.

Subject to the above, with respect to any such Goods during the Warranty Period, Seller shall, in its sole discretion, either: (i) repair or replace such Goods (or the defective part) or (ii) credit or refund the price of such Goods at the pro rata contract rate provided that, if Seller so requests, Buyer shall, at Seller's expense, return such Goods to Seller.

THE REMEDIES SET FORTH THIS OPERATION AND SAFETY MANUAL SHALL BE THE BUYER'S SOLE AND EXCLUSIVE REMEDY AND SELLER'S ENTIRE LIABILITY FOR ANY BREACH OF THE LIMITED WARRANTY SET FORTH IN THIS OPERATION AND SAFETY MANUAL.

This Limited Warranty Does Not Include:

- (a) Any labor charges for troubleshooting, removal, or installation of such parts;
- (b) Any repair or replacement of such parts necessitated by faulty installation, improper operating procedures and conditions, misuse, abuse, negligence, accident, fire, flood, repair materials, and/or unauthorized accessories;
- (c) Any products installed without regard to required local codes and accepted trade practices;
- (d) Damage caused by water passing through the unit;
- (e) Damage caused by operating below or above specified working pressure;
- (f) Any implied warranty of merchantability or implied warranty of fitness for a particular purpose, which are hereby disclaimed; and
- (g) Purifico Ozone Inc. shall not be liable under any circumstances for loss of use of such products, lost profits, direct damages, indirect damages, consequential damages, and/or incidental damages.
- (h) Any shipping / freight costs associated with the warranty claim.

NOTE: Any work performed on Purifico Ozone Inc. products without prior authorization from Purifico Ozone Inc. will automatically void this warranty. The ozone cell contains tamper-proof devices; any attempt to open the cell will void the warranty and eliminate the possibility of obtaining any service from Purifico Ozone Inc.

To Obtain Warranty Service:

Please provide the following information:

- Project, contact name, mailing address, and telephone number
- Installer/Mechanical Contractor
- Date of purchase
- Date of failure
- System serial number
- A description of the failure
- All shipping documents should clearly state “Warranty Repair” and indicate the RMA number.
- Purifico Ozone Inc. is not responsible for double taxes or duties resulting from improper shipping documentation.

Contact Information:

Purifico Ozone Inc.
9409 – 45 Ave NW
Edmonton, Alberta, T6E-6B9
Canada
Toll Free: +1-888-353-0021
Email: accounting@purifico-ozone.com
Web: www.purifico-ozone.com

1. Limitation of Liability

IN NO EVENT SHALL SELLER BE LIABLE FOR ANY CONSEQUENTIAL, INDIRECT, INCIDENTAL, SPECIAL, EXEMPLARY, OR PUNITIVE DAMAGES, LOST PROFITS OR REVENUES OR DIMINUTION IN VALUE, ARISING OUT OF OR RELATING TO ANY BREACH OF THESE TERMS, WHETHER OR NOT THE POSSIBILITY OF SUCH DAMAGES HAS BEEN DISCLOSED IN ADVANCE BY BUYER OR COULD HAVE BEEN REASONABLY FORESEEN BY BUYER, REGARDLESS OF THE LEGAL OR EQUITABLE THEORY (CONTRACT, TORT OR OTHERWISE) UPON WHICH THE CLAIM IS BASED, AND NOTWITHSTANDING THE FAILURE OF ANY AGREED OR OTHER REMEDY OF ITS ESSENTIAL PURPOSE.

IN NO EVENT SHALL SELLER'S AGGREGATE LIABILITY ARISING OUT OF OR RELATED TO THIS AGREEMENT, WHETHER ARISING OUT OF OR RELATED TO BREACH OF CONTRACT, TORT (INCLUDING NEGLIGENCE) OR OTHERWISE, EXCEED THE TOTAL OF THE AMOUNTS PAID TO SELLER FOR THE GOODS SOLD HEREUNDER [or TEN THOUSAND DOLLARS (\$10,000), WHICHEVER IS LESS].

The limitation of liability set forth in this Operation and Safety Manual shall not apply to (i) liability resulting from Seller's gross negligence or wilful misconduct and (ii) death or bodily injury resulting from Seller's acts or omissions.

2. Governing Law

All matters arising out of or relating to this Agreement are governed by and construed in accordance with the laws of the Alberta and the federal laws of Canada applicable therein without giving effect to any choice or conflict of law provision or rule (whether of Alberta or any other jurisdiction) that would cause the application of the laws of any jurisdiction other than those of the Alberta. The United Nations Convention on Contracts for the International Sale of Goods does not apply to this Agreement.

3. Choice of Forum

Any legal suit, action, litigation or proceeding of any kind whatsoever in any way arising out of, from or relating to this Agreement, including all exhibits, schedules, attachments, and appendices attached to this Agreement, and all contemplated transactions, shall be instituted in the courts of Alberta, and each party irrevocably submits to the exclusive jurisdiction of such courts in any such suit, action, litigation or proceeding. Service of process, summons, notice, or other document by mail to such party's address set forth herein shall be effective service of process for any suit, action, litigation or other proceeding brought in any such court. Each party agrees that a final judgment in any such suit, action, litigation, or proceeding is conclusive and may be enforced in other jurisdictions by suit on the judgment or in any other manner provided by law.